



NAVCO®

Houston, Texas

HCP 3.L0 SG0

Hopper Car Portable



Operating Characteristics

FREQUENCY	1450 vpm
AIR CONSUMPTION	14 S.C.F.M @ 50 psi

The **NAVCO** HCP 3.L0 SG0 pneumatic piston vibrator is designed to provide reliable and effective performance in difficult applications and severe environments. The size and operating characteristics of the HCP 3.L0 SG0 make it ideal for solving Heavy-Duty railcar unloading problems.

Operation and Construction

The HCP 3.L0 SG0 vibrator incorporates a nominal 3" piston and bore. The vibrator housing is manufactured from a one piece, ductile iron casting. During operation, compressed air is alternately directed from one end of the piston to the other through a series of internal ports. The piston is the only moving part, which makes the HCP 3.L0 SG0 vibrator a reliable, low maintenance device.

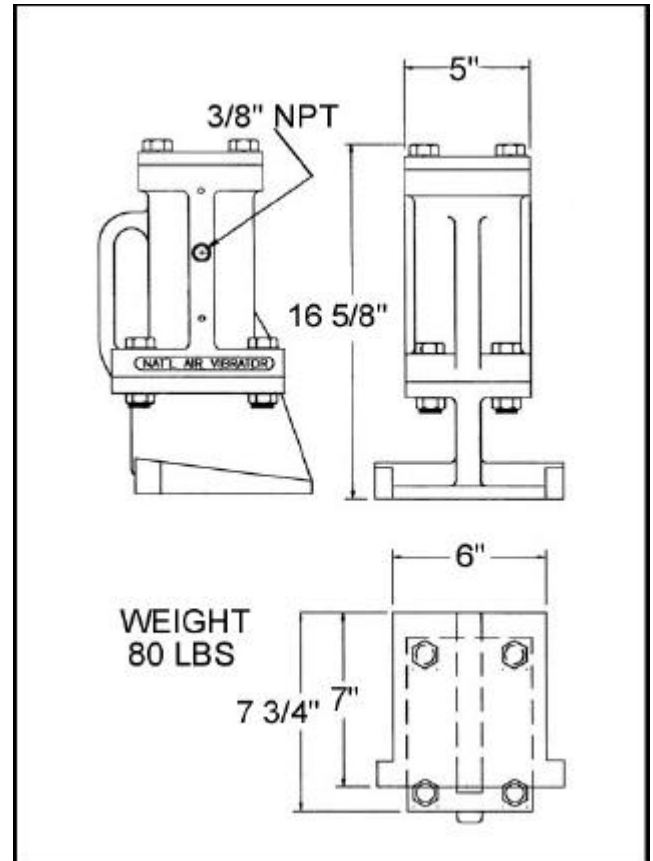

All internal surfaces are coated with Teflon, to enhance the durability and reliability of **NAVCO** HCP 3.L0 SG0 vibrators.

The HCP 3.L0 SG0 mounting head (B-271) is universal and fits all dove-tail brackets common on hopper cars. Manufactured with tabs on both sides, the mounting head provides a loose fit in the bracket.

The loose fit, "free-ride" design is a **NAVCO** feature offering the following advantages:

- ?? High amplitude, low frequency action of the HCP 3.L0 SG0 piston moves the total mass of the vibrator back & forth in the dove-tail bracket. This is the most effective and efficient means to transmit vibration energy through the railcar hopper to the bulk material.

?? Many railcar manufacturers recommend only high amplitude, low frequency vibrators to minimize stress fatigue and railcar maintenance costs.

?? The "free-ride" design allows for easy installation and removal of the **NAVCO** hopper car vibrators.

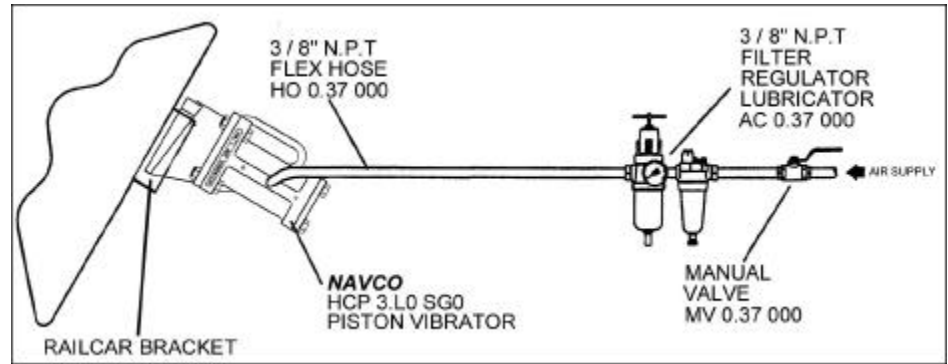

The HCP 3.L0 SG0 allows for fast, efficient unloading of cement, fertilizers, soybean meal, feeds, sugar, salt cake, clays, lime, soda ash, or other materials - freeing personnel for other duties and reducing "carry back". Additionally, the HCP 3.L0 SG0 eliminates hazardous scraping of interior walls from on top of the railcar.

Model Types

The standard **NAVCO** HCP 3.L0 SG0 is offered as a silent model. The silent model operates at a frequency and amplitude to optimize the advantages of the "free-ride" design.

NAVCO HCP 3.L0 SG0 pneumatic piston vibrators are excellent for all bulk material flow problems from railcars, especially those involving cohesive materials with marginal to poor flow characteristics. They are also effective in cleaning material adhering to railcar hopper walls.

Installation

The HCP 3.L0 SG0 is designed to fit loosely in hopper car brackets. The unit should be allowed to move freely in the bracket.

Care should be taken to keep supply air lines free from contaminants as hopper car vibrators are continuously installed and removed from railcars.

Recommended operating pressure is 20 to 60 p.s.i. (at the vibrator). A well-designed air supply line system is also recommended to allow filtered and lubricated air to reach the vibrator, thus increasing vibrator life.

Automatic on / off cycling is recommended to optimize the unloading process. Other benefits of cycling include extended vibrator life, reduced utility costs, and lower average noise levels.

Accessories

NAVCO offers all air line accessories for complete installation of HCP 3.L0 SG0 vibrators.

HCP Cart

NAVCO has also developed a sturdy hand cart for all HCP models. The cart is constructed of tubular steel with pneumatic tires to roll over obstructions. The unique cart design allows for easy installation and removal of HCP's from the car brackets. The HCP Cart has several advantages over manual installation and removal of HCP's.

?? Simple lever design makes installation and removal of the heaviest HCP's easy.

?? Eliminates back strain from manual installation and removal.

?? Prevents dirt and other contaminants from entering the exhaust ports.



The **NAVCO** HCP 3.L0 SG0 is the ideal solution for Heavy-Duty railcar unloading. High amplitude, low frequency vibration developed by the HCP 3.L0 SG0 effectively and efficiently facilitates the flow of bulk materials from railcar hoppers.

Contact **NAVCO** or the local sales representative listed below for more information or solutions to other bulk material flow problems.

NAVCO

P.O. Box 40563, Houston TX 77240-0563

Ph: (832) 467-3636 Fax: (832) 467-3800

TOLL FREE 1-800-231-0164

www.navco.org navcosales@navco-jvi.com

Represented By: