

Mink

Claw Vacuum Pumps MM 1402/1502 AV



Mink claw vacuum technology by Busch offers the highest level of energy efficiency for industrial vacuum generation, combined with the lowest level of maintenance and consistent performance. With the addition of the MM 1402 AV and the MM 1502 AV, these advantages are also offered for applications that require higher pumping speeds.

The sophisticated claw vacuum technology of Mink vacuum pumps allow for decreased energy consumption and increased performance. Due to this, substantial energy savings are possible in comparison with conventional vacuum technology when operated at the same pumping speed.

Additionally, claw vacuum technology is virtually maintenance free due to its non-contacting design. As a result, wear in the pumping chamber is completely eliminated.

Maintenance in the pumping chamber, such as inspection and replacement of worn parts, is not necessary. Since operating fluids are not needed in the pumping chamber for these dry compression, air-cooled pumps, there are no additional costs for purchase, provision or disposal.

The non-contacting, dry compression operation of Mink claw vacuum pumps allow for high operational reliability and long life cycles. Without wear in the pumping chamber, vacuum and suction performance remains consistently high throughout the life cycle of the pump. Additionally, a smart silencer design enables quiet operation.



**Mink – save on energy
and operating costs for
vacuum generation.**



Mink MM 1502 AV

Mink

Claw Vacuum Pumps MM 1402/1502 AV



Technical specifications

With Mink vacuum pumps, two claw-shaped rotors turn in opposite directions inside the housing. Due to the shape of these claw rotors, the air or gas is sucked in, compressed and discharged. The claw rotors do not come into contact with each other or with the cylinder in which they are rotating. Tight clearances between the claw rotors and the housing optimize the internal seal and provide a consistently high pumping speed. A synchronization gearbox ensures exact synchronization of the claw rotors. Mink vacuum pumps are driven by a directly flange-mounted motor.

Industrial vacuum generation for many applications

Mink claw vacuum pumps are available in a wide range of sizes. Special models for certain applications such as dust and gas explosion protection, high water vapor contents, gas tightness, increased oxygen contents, etc., are also available. Contact a knowledgeable Busch application specialist for additional information.

Mink MM 1402/1502 AV

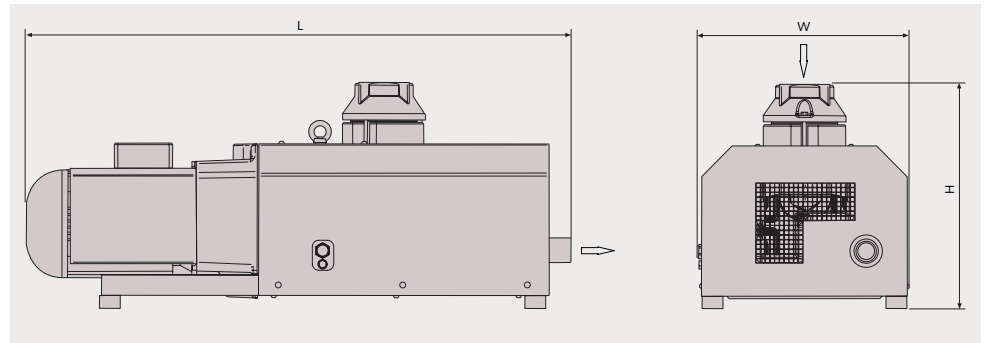

Pumping speed Air at 70 °F. Tolerance: ± 10%

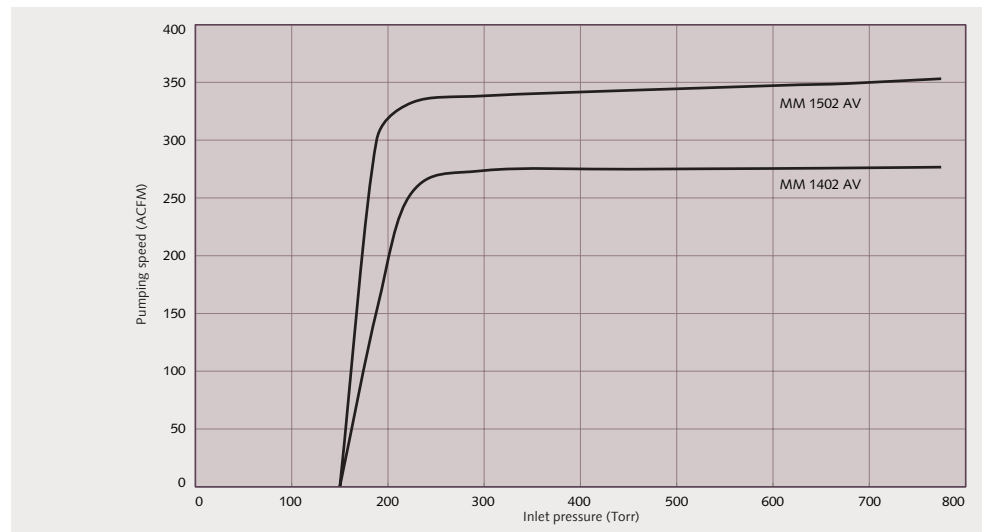

Technical Data		MM 1402 AV	MM 1502 AV
Nominal pumping speed	ACFM	277	353
Ultimate pressure	Torr	150	150
Nominal motor rating	kW (HP)	9.5 (12.7)	12.6 (16.9)
Nominal motor speed	RPM	3600	3600
Sound level (ISO 2151)	dB(A)	83	82
Approximate weight	Lbs	706	717
Dimensions (L x W x H)	inches	51 5/8 x 20 1/4 x 21 1/2	51 5/8 x 20 1/4 x 21 1/2
Gas inlet / outlet	NPT	3" / 2"	3" / 2"

All performance data is based on ambient conditions of 14.7 PSIA and 70 °F, and has a tolerance of ± 10%.

Busch LLC

516 Viking Drive | Virginia Beach, VA 23452 | Phone 757-463-7800 | marketing@buschusa.com | www.buschusa.com

Argentina Australia Austria Belgium Brazil Canada Chile China Czech Republic Denmark Finland France Germany Hungary India Ireland Israel Italy Japan Korea Malaysia Mexico New Zealand Netherlands Norway Poland Portugal Russia Singapore South Africa Spain Sweden Switzerland Taiwan Thailand Turkey United Arab Emirates United Kingdom USA

Technical data is subject to change. Created in Germany 06/N