

Item#	Qty	Description	Comments
1	1	Frame, Main	Height to customer req.
2	1	Hopper, Bag Gyrator	Can be plain or stainless steel
3	4	Isolators	Shock Mounts
4	1	Gyrator Motor	Air-powered or electric motor.
5	1	Fork Lift Adapter Frame	Formpak PN 100-FA
6	2	Fork Lift Adapter Receiver	Formpak PN 101-AR.
7	1	Access Box	Can be plain or stainless steel
8	4	Hitchpin, W/Hairpin Clip	DoubleHH 00233
9	1	Iris Valve	Our most popular option
10	1	Hopper, Lift Motor, Flex Screw	Discharge: 16'
11			
12			
13			
14			
15			

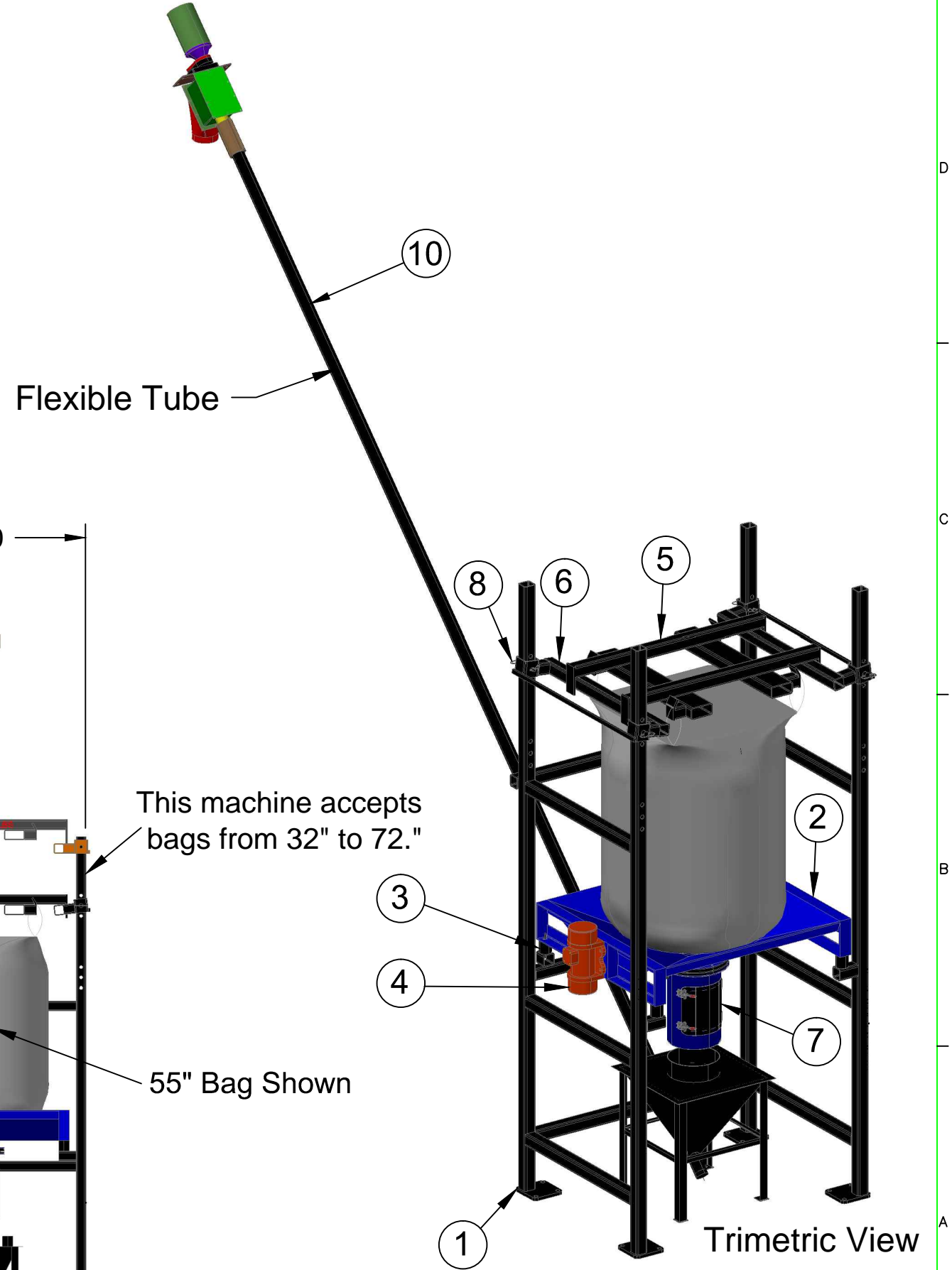
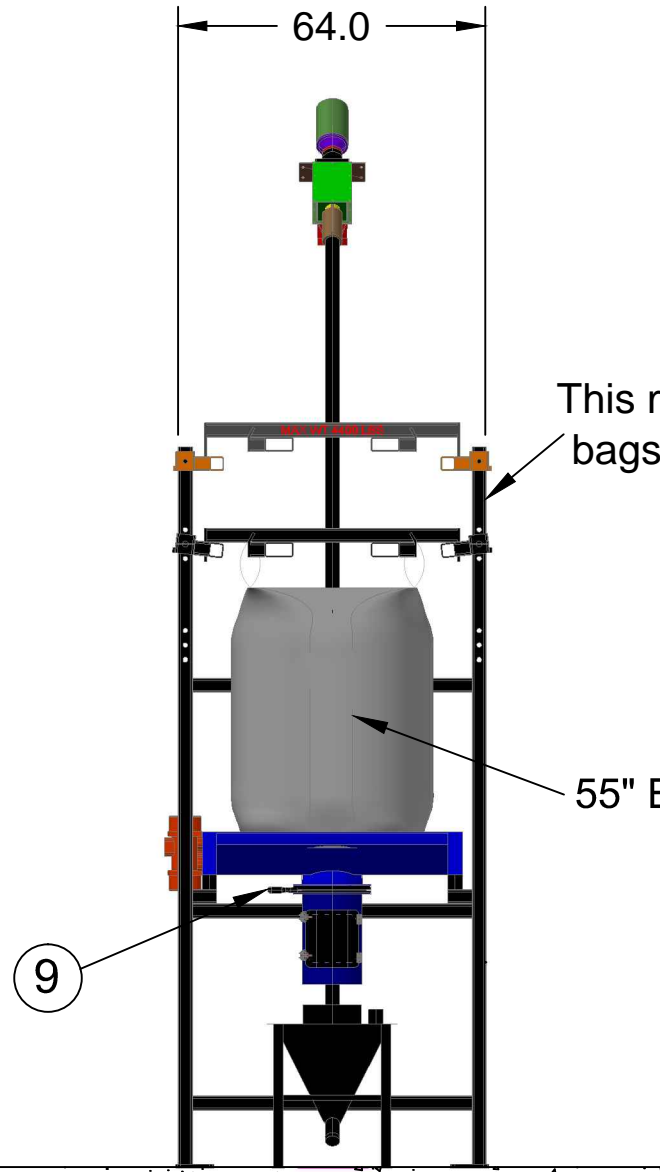
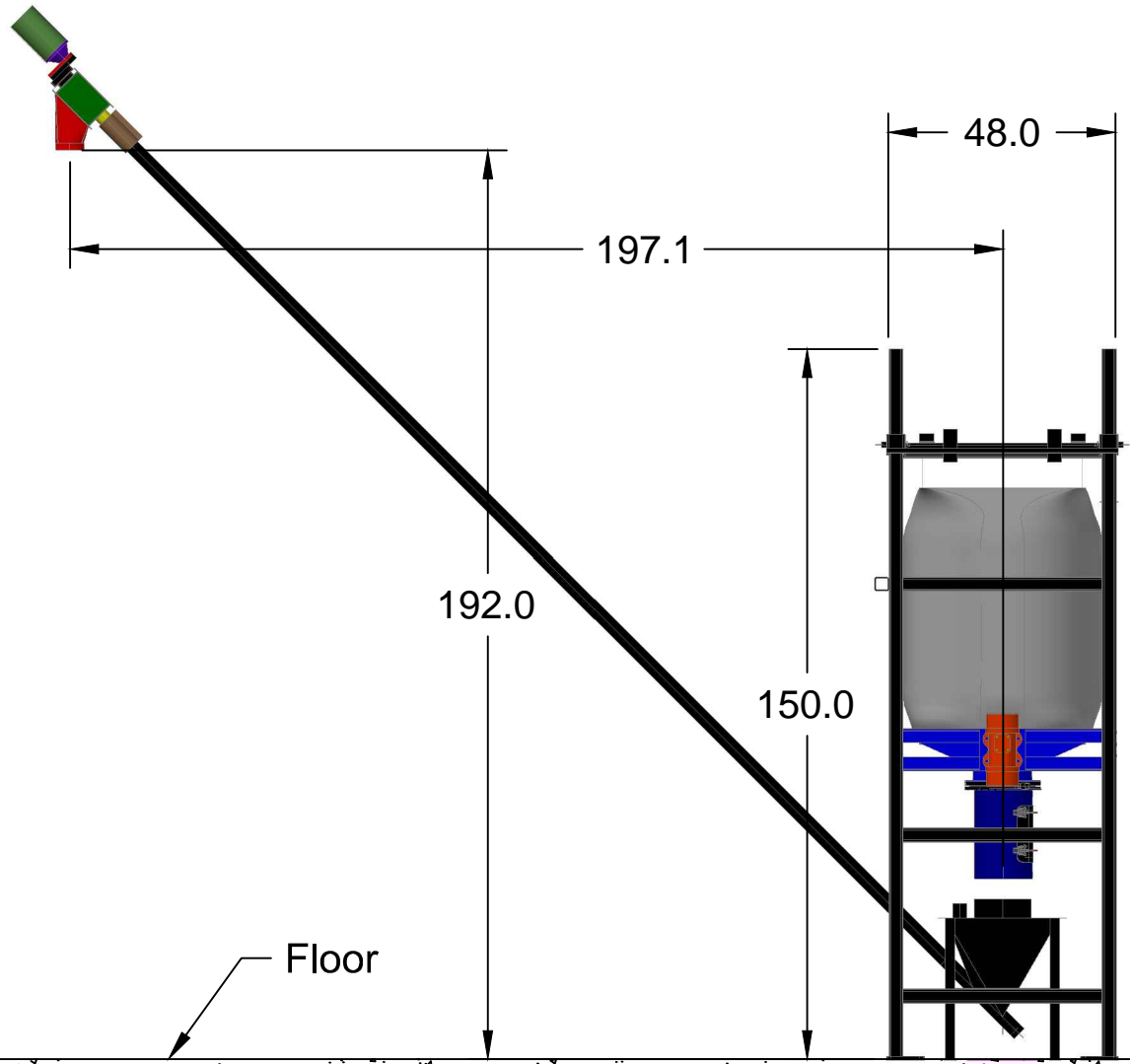
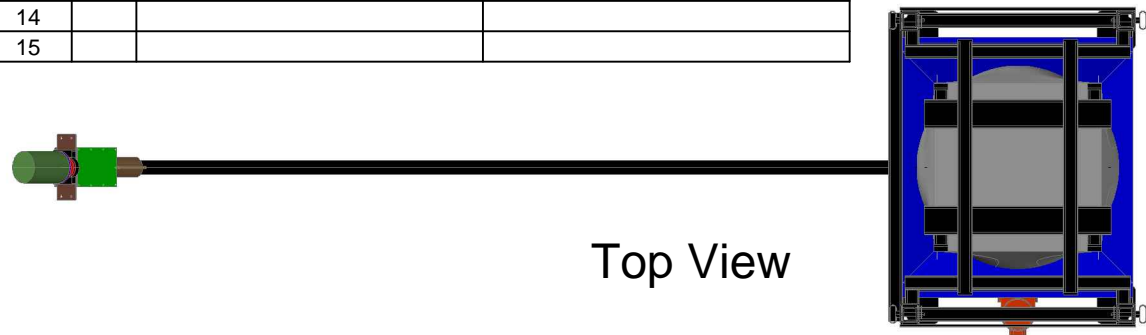

**FormPak Inc.**  
Meeting Your Materials Handling Needs Since 1968

BagFlo 500-FL (ForkLift) Assembly  
with Flex Screw 16' Rise

Date: 1/18/2011  
Scale: 1/25  
Sheet No.: 1 of 1  
Dwg No.: 000056