



PACKAGING SOLUTION

FOR THE
**PET FOOD
INDUSTRY**

Bagging machines for preformed bags



High speed bag filling and closing machine for preformed bags, complete with Concetti net weigher and belt infeed system

IPF 25™

1-7 kg
one filling spout
up to 1000 bags/h

IPF 40™

1-7 kg
two filling spouts
up to 1800 bags/h

IGF™

2-20 kg
one filling spout
up to 1000 bags/h

IMF™

2-20 kg
two filling spouts
up to 1800 bags/h

Main advantages

- Changover in 90 seconds without the use of tools.
- Accurate handling of the most advanced PE, PET, Alu gusseted bags, "single lip" bags, stand-up pouches etc.

Unique features



- Single or double heat-sealing of bags at different heights on the bag face, fully programmable

- High-capacity empty bag magazines

- Gusset holding and restoring devices for flawless handling of bags, specifically designed for Stabilo or Quad seal bags, patented

- Pinch-top sealing



- Optional device to add a resealable zip closure on the top of the bag

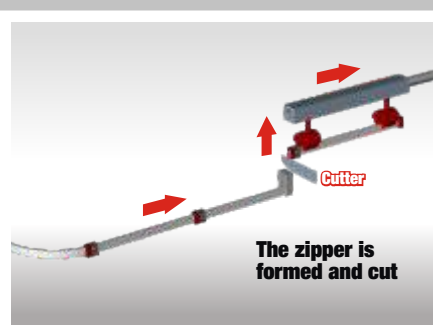

- Optional device to form bags from a gusseted tubular reel

Bags from a tubular reel



CONCEPTA™
complete with
Concetti net weigher
and belt in-feed
system

CONCEPTA™ is the FFS-machine that forms bags from a tubular gusseted reel, fills and seals them.

Weight range for pet food:

4 to 20 kg

Output:

up to 1400 bags/hour

Unique features



- Optional device to create bags with carrying handles

- Optional device to apply a resealable zip closure on the top of the bag

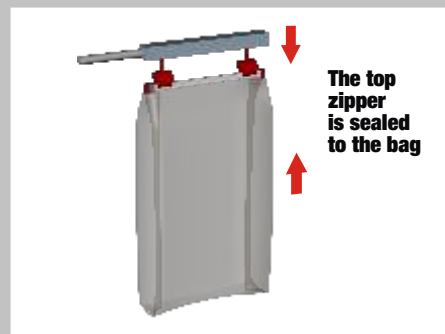
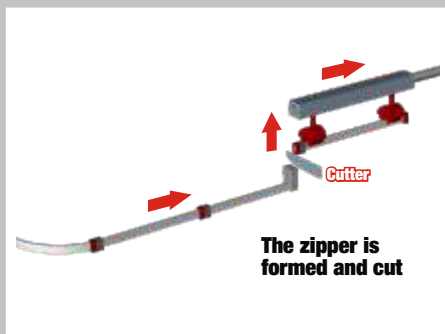

- Optional device to extract the excess air from the bag prior to sealing

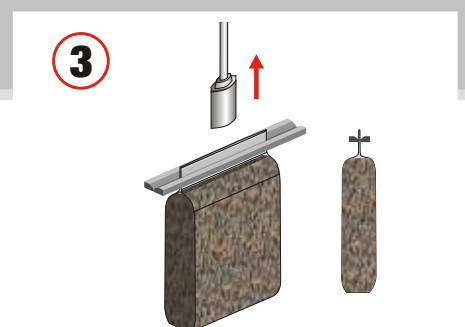
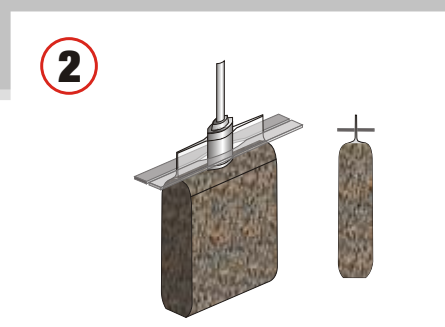
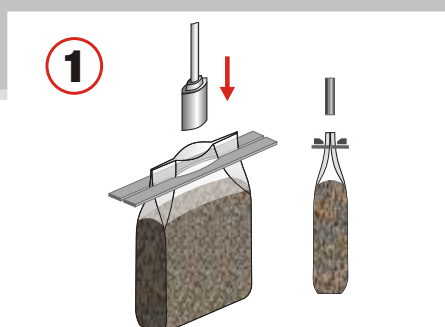

PS-3A™ FOUR-COLUMN ROBOT PALLETISER

- Possibility to overlap bags to ensure loads are inside the pallet dimensions
- Top and side compression for excellent pallet stability and shape
- A special gripper tool can take one or two bags at a time
- Top speed of 1800 bags/hr, according to the bag size and the layer pattern



PS-3A™ FOUR AXIS PALLETISING ROBOT

It features a gripping tool for bags or a gripping tool for boxes.

Top speed: 900 cycles/h



TURN-KEY BAGGING AND PALLETIZING LINE



The Concetti Group manufactures complete packaging lines that include in-house built weighers, bag fillers and palletizers

Ancillary equipment pieces can be integrated to the Concetti lines:

- metal detectors
- check weighers
- printers and labellers
- special conveyors
- wrapping or hooding machines
- supervisory systems



CONCETTI S.p.A.

S.S.75 C. U. Km 4.190 Fraz. Ospedalicchio
06083 BASTIA UMBRA (Perugia) ITALY
Tel. +39 075 801.561 Fax +39 075 800.0894



CBC srl

S.S.75 C. U. Km 4.190 Fraz. Ospedalicchio
06083 BASTIA UMBRA (Perugia) ITALY
Tel. +39 075 808.151 Fax +39 075 808.1508

sales@concetti.com

