

Manual Lift Cart

for Rail Car Portable Vibrators

FEATURES:

- Simple rugged design for easy use.
- Wide wheelbase designed for stability.
- Large wheels make rolling easy.
- Handle is ergonomically located for comfort.
- Smooth HCP lifting and lowering action.
- Ends lifting of heavy vibrators.
- Kick stand for safe, stable resting position.
- Moves any size HCP effortlessly.

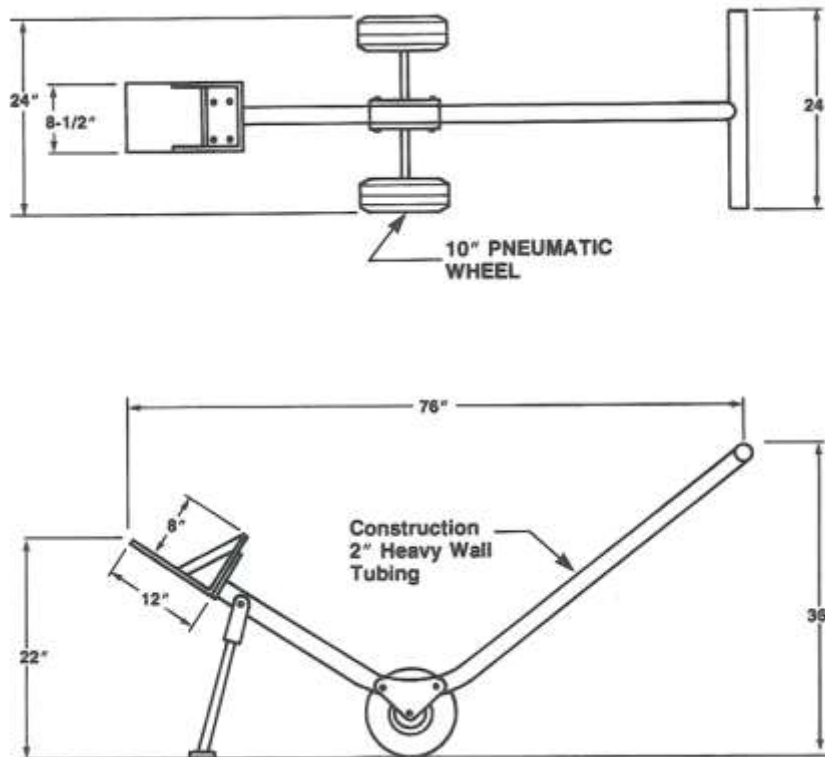

OPERATION

The HCP Manual Lift cart is simply rolled up to the HCP sitting in a dovetail bracket. Pressing down on the handlebars will raise the cradle and lift the HCP out of the dovetail bracket; the cart is then rolled backwards to disengage it from the railcar. The HCP can be placed on a dovetail bracket in the same fashion, by raising the cart's cradle over the bracket, pushing the cart forward slightly, then lowering the cradle.

Move HCPs Effectively

P.O. Box 40563, Houston TX 77240-0563
 Ph: (832) 467-3636 Fax: (832) 467-3800
TOLL FREE 1-800-231-0164
 www.navco.us sales@navco.us

NAVCO[®]
 HOUSTON, TX