



*The
Sampling
Connection*



MODEL MIL IN-LINE SAMPLER

Representative Liquid Sampling from Process Lines

Features

- Close-coupled sampling valve for high pressure low dead volume in-line sampling
- Needle or tube stub configurations in a variety of sizes

Options

- Variety of end connections
- Optional enclosure for complete containment

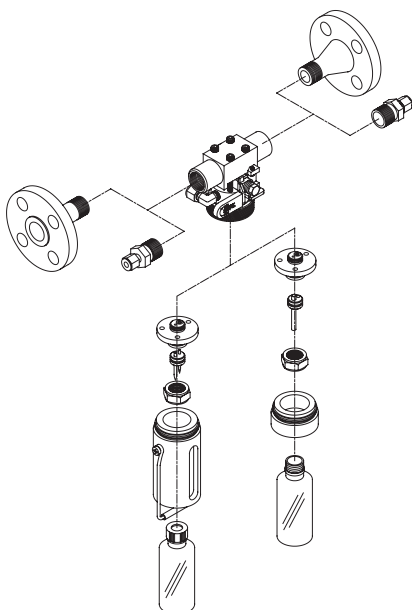

Description

The Sentry in-line sampler has unique features compared to other in-line process samplers. By using a close-coupled ball valve specifically designed to provide low dead volume in the sample flow area, the Sentry in-line sampler ensures accurate and representative samples from flowing process lines at pressures up to 2200 psig (150 barg). Additionally, the pressure drop of the flowing fluid through the sampler is low and there are no valve stems or other components passing through the sampling stream.

In-line sampling techniques are most applicable where speed loops or other pressure reduction techniques are not viable. The Sentry in-line sampler uses Sentry's standard side-discharge dual needle assembly that ensures septum integrity and full venting of process vapors. This patented no-coring needle design punctures the septum without cutting it, allowing for full resealing of the septum when the sample bottle is removed. The tapered bottle shroud assures proper septum and needle alignment preventing accidental spillage or needle breakage. A variety of needle arrangements and sample bottle sizes are available to meet most sampling requirements. Additionally, a tube stub option is available for high viscosity fluids or those that contain particulates. A sample purge connection is a standard feature that allows the user to clear any remaining sample from the unit after sampling. The purge process can be as simple as a check valve and air puff bulb or regulated compressed air/nitrogen.

Since operator safety is of the highest concern, the sampling valve interface features an adjustable throttle stop and spring return handle. This provides proper sample control and quick closure upon release of the sampling valve.

IN-LINE SAMPLER OPTIONS

Size Chart

Size	Designator		
	NPT	FLG	COMP
1/4" (6 mm)			C1/4
3/8" (10 mm)			C3/8
1/2" (15 mm)	N1/2	F1/2	C1/2
3/4" (20 mm)		F3/4	C3/4
1" (25 mm)		F1	C1
1 1/2" (38 mm)		F1-1/2	

Sampler Interface

Needle Assembly (O.D.)		
Process	Vent	Designator
0.065"	0.065"	11
0.065"	0.083"	12
0.083"	0.083"	22
0.110"	0.083"	32
0.083"	0.110"	23
Tube Stub Assembly (O.D.)		
0.188"	0.140"	44

- Add V for Viton® or K for Kalrez® to specify O-rings.
- Consult factory for other needle/tube stub arrangements.

Sample Bottle Size and Type

Boston Round		Schott/Duran	
Size: oz. (ml)	Designator	Size: ml	Designator
2 (60)	B2	50	S50
4 (125)	B4	100	S100
8 (250)	B8	250	S250
16 (500)	B16	500	S500
32 (1000)	B32	1000	S1000

- Add S for septum cap (needle assembly) or P for plain cap (tube stub assembly). Boston Round bottle cap/thread interfaces per GPI finish standards. Schott/Duran bottle cap/thread interfaces per ISO 4796. Glass vials available in 4, 20 or 40 ml.
- Standard septum material is Teflon®-coated silicone.
- Consult factory for other bottle or septum arrangements.

SPECIFICATIONS

Wetted materials, body	316 stainless steel
Wetted materials, O-rings	Viton®, Kalrez®
Wetted material, shroud	Nylon
Pressure rating	2200 psig max@ 100°F (150 barg @ 38°C)
Pressure rating, other	100 psig max@ 450°F (7 barg @ 232°C)
Pressure rating, note	flange end connections have lower ratings — consult factory
CV	30.0
Sample valve	close coupled ball valve with spring return handle and adjustable throttling stop
Purge Connection	1/8" compression (shipped with cap)

⚠ WARNING

It is solely the responsibility of the end-user, through its own analysis and testing, to select products and materials suitable for their specific application requirements, ensure they are properly installed, safely applied, properly maintained, and limit their use to their intended purpose. Improper selection, installation, or use may result in personal injury or property damage.

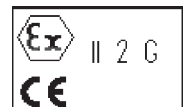

SENTRY EQUIPMENT CORP

PO Box 127
Oconomowoc, WI 53066 USA
Phone: 262-567-7256
Fax: 262-567-4523

E-mail:
sales@sentry-equip.com

Website:
www.sentry-equip.com

For further information, contact:

The Sampling Connection