



*The
Sampling
Connection*

MODEL A AUTOMATIC SAMPLER

Automatic Sampler for Free-Flowing Bulk Solid Materials

Features

- Compact, easy to mount
- Low maintenance
- Product contact materials are 304 stainless steel
- Includes a sampler, air filter, regulator and air gauge

Options

- Custom mounting adapters
- Custom slide construction
- Custom construction materials
- Nickel-impregnated Teflon® for a non-stick surface
- Hardening treatments to protect against wear and abrasion



MODEL A AUTOMATIC SAMPLER

Description

The Model A sampler is designed for automatic sampling of free-flowing materials such as granules, coarse powders, flakes and pellets from screw or drag conveyors.

The Sentry Model A takes a sample when a solenoid-controlled air cylinder opens a sliding gate on the sampler, then closes the gate.

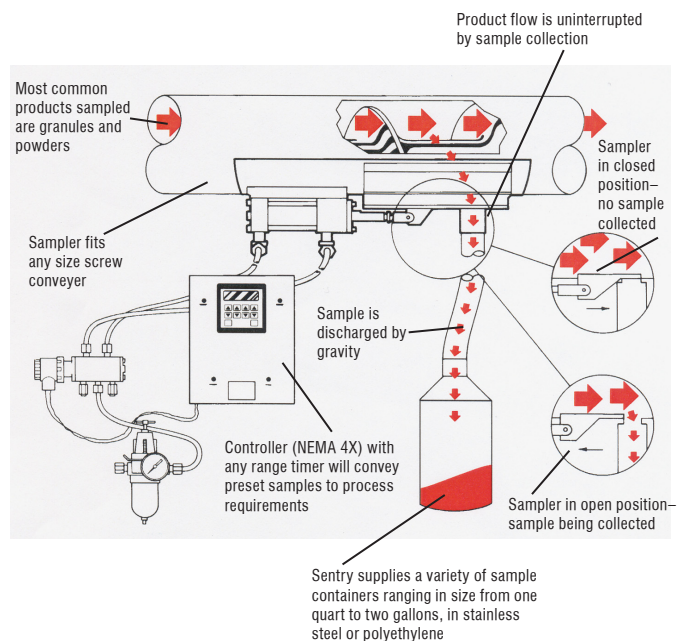

MODEL A TECHNICAL DATA

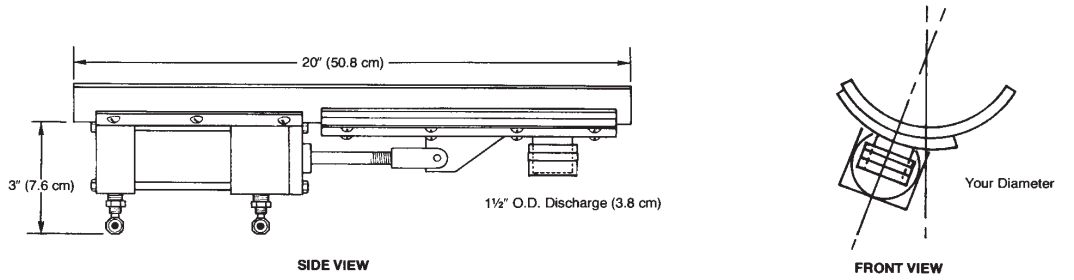

VARIOUS MOUNTS

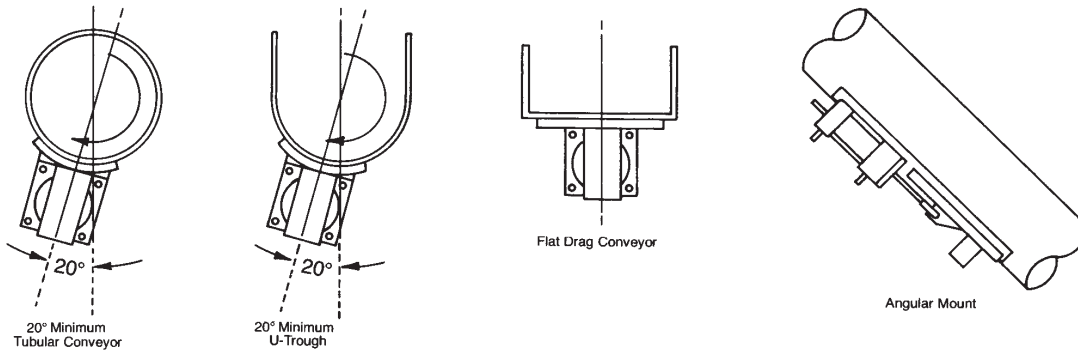

SPECIFICATIONS

Basic Electrical Requirements for Control	115/230 VAC, single phase, 60 Hz; control box fused to 2 amps
Air Requirements	80 psig, 1.5 cfm per cycle
Quantity of Sample	determined by flow rate, aperture size and time in line
Product Size	10 micron to 1/4" / 6 mm; larger sizes upon request
Recommended Location of Sampler	screw conveyors or angled gravity chutes
Suggested Connection to Collection Point	rigid metal or flexible tubing to a collection container or multi-position collection cabinet
Materials of Construction	304 stainless steel; acetal spacers and urethane wiper seal
Temperature Range	up to 250°F / 121°C

⚠ WARNING

It is solely the responsibility of the end-user, through its own analysis and testing, to select products and materials suitable for their specific application requirements, ensure they are properly installed, safely applied, properly maintained, and limit their use to their intended purpose. Improper selection, installation, or use may result in personal injury or property damage.



SENTRY EQUIPMENT CORP

PO Box 127
Oconomowoc, WI 53066 USA
Phone: 262-567-7256
Fax: 262-567-4523

E-mail:
sales@sentry-equip.com

Website:
www.sentry-equip.com

For further information, contact:

The Sampling Connection